

AutoLabel 500P™ Thermal Transfer Printer

Superior and accurate inline
printing to increase productivity
in small to medium size bag
packaging applications



Markets Served



FEATURES AND BENEFITS

- Fully integrated packaging is achieved by combining the 500P™ with the 500™ bagger, along with AUTOBAG brand or third party scales, counters or conveyors
- Available in 203, 300, and 600 dpi resolution
- Print Speeds up to 12" per second (600 dpi up to 6" per second)
- Improved bag web flow for tighter registration and more reliable bag sensing
- No air required, minimal electrical requirements
- More flexible, accessible design for ribbon loading and maintenance
- System-matched AUTOBAG brand pre-opened bags, AutoLabel Thermal Transfer Ribbon, and Autolabel Design Software
- AutoLabel Thermal Transfer Ribbons ensure the highest print quality on AUTOBAG brand bags and extend printhead life
- Resident Linear Barcodes: Code 3 of 9, UPC-A, UPC-E, Interleaved 2 of 5, Industrial 2 of 5, Std 2 of 5, Code 11, Code 93, Code 128, EAN-8, EAN-13, HIBC, Codabar, Plessey, UPC 2 and 5 digit addendums, Postnet, UCC/EAN Code 128, Telepen, Planetcode, FIM, USPS-4 State
- Resident 2D Barcode Symbologies: MaxiCode, PDF417, USD-8, Datamatrix, QR Code, Codeablock, Code 16k, Aztec, TLC 39, Micro PDF417, GS1 Databar

Technical Information

WEIGHT

455 lbs. with 500; 65 lbs. alone

ELECTRICAL

100V to 240V VAC, 50/60 Hz Power
Consumption: 800 Watts with 500;
300 Watts (VA) alone

AIR FEED

No air required

BAG SIZES

W2 to 12 in. L * 2.5 to 20 in.
(36 in. L unsupported)

*There are two versions, Long and Short.
Long configuration min length is 5 in. Short min length is 2.5 in.

LABEL SIZES

Up to 4" wide; up to 20" long

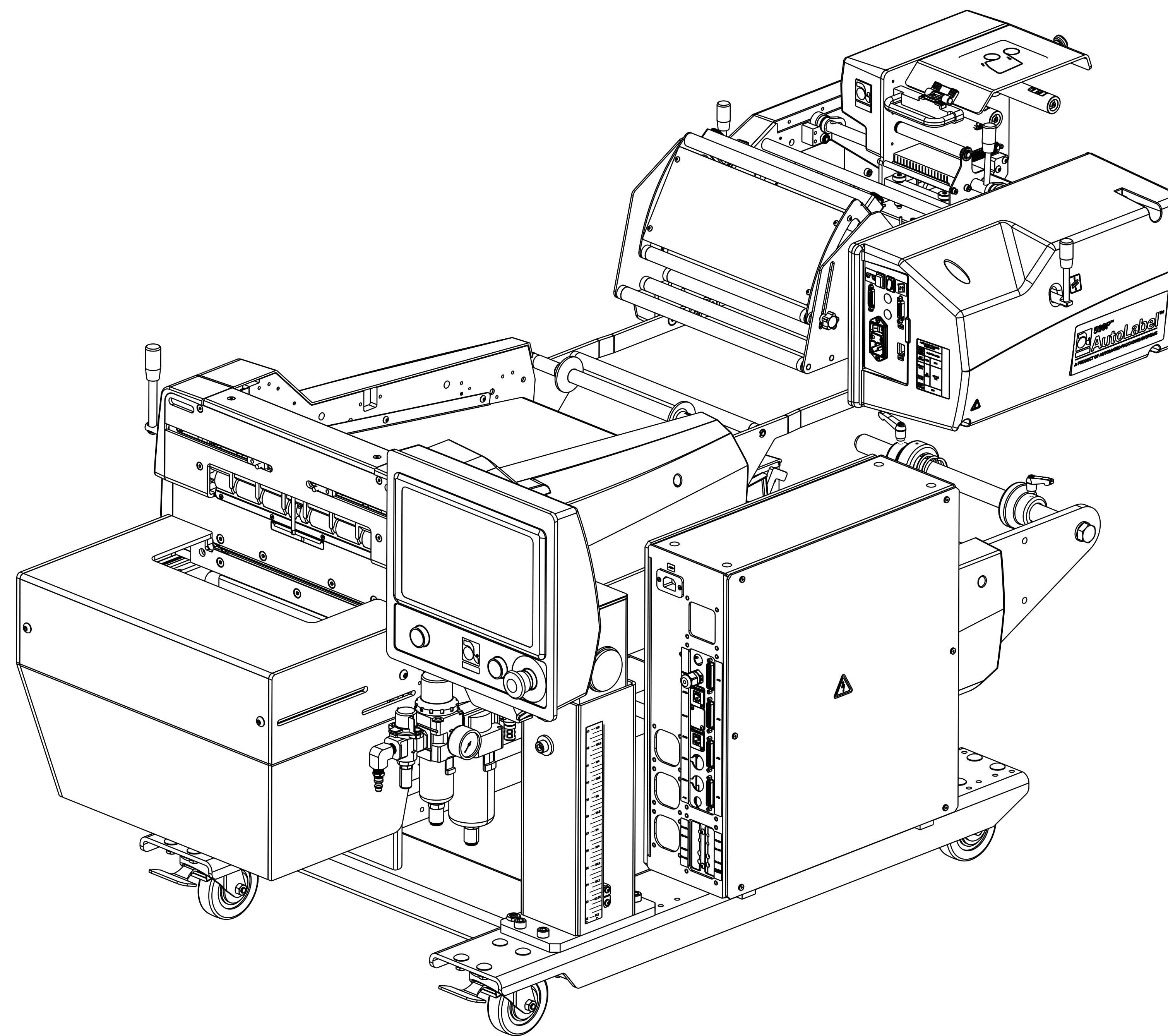
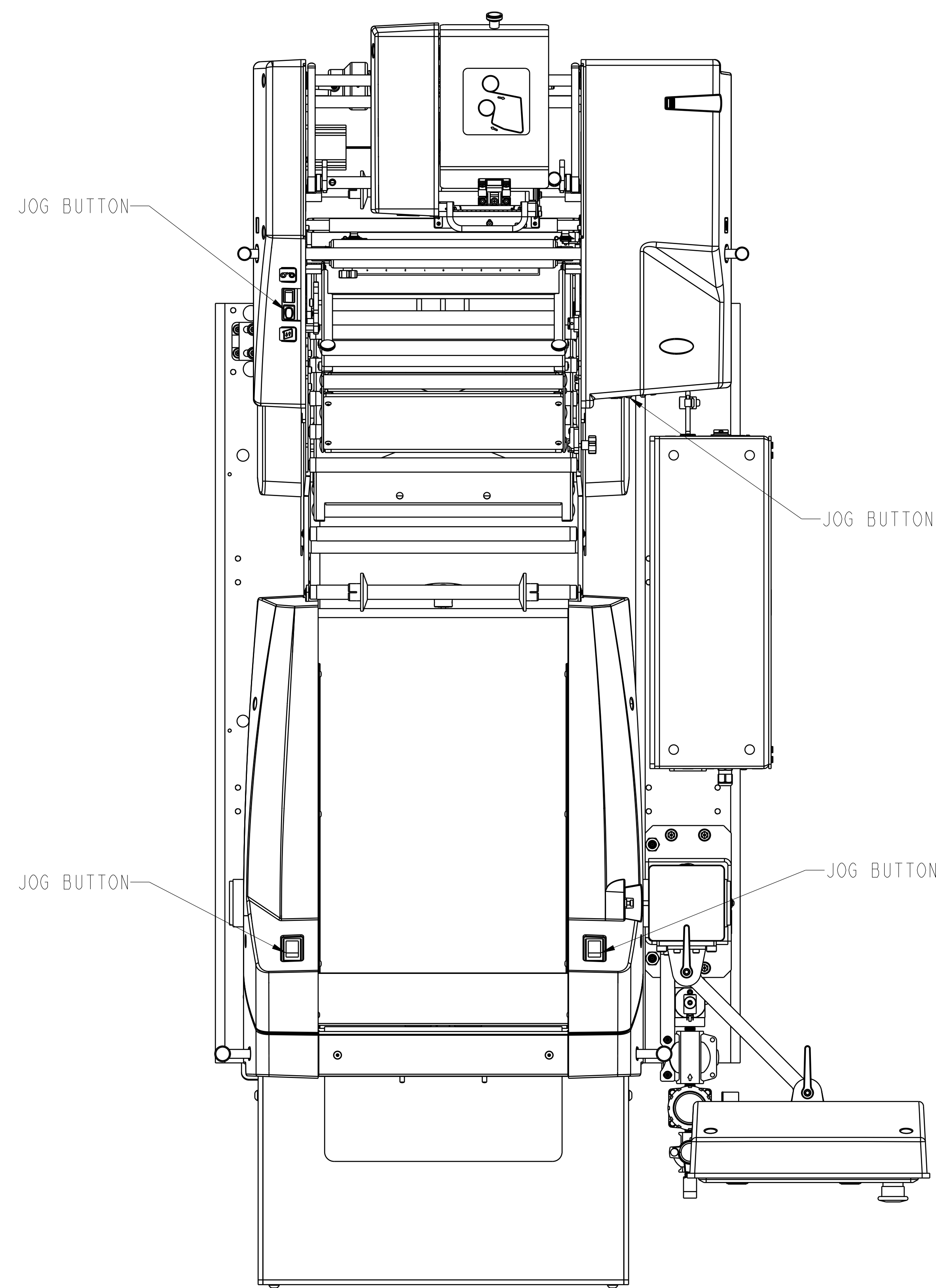

BAGGER SPECIFICATIONS	
WEIGHT	350 LBS (158.6 KG)
ELECTRICAL	UNIVERSAL INPUT, 100V TO 240V VAC, 50/60 Hz POWER CONSUMPTION: 500W (VA) MAX
AIR FEED	5 CFM/80 PSI OF CLEAN, DRY AIR
PASS-THROUGH	UP TO 5 INCHES (127 MM)
BAG THICKNESS	1.09 - 4.0 MIL
BAG SIZES	WIDTH: 2 TO 12 INCHES (51 TO 305 MM) / LENGTH: 3 TO 20 INCHES (76 TO 508 MM)
WEIGHT CAPACITY	UP TO 5 LBS (WITH LOAD SHELF)

PRINTER SPECIFICATIONS	
WEIGHT	66 LBS (30 KG)
ELECTRICAL	100-240V VAC, 50/60 Hz, 300W
AIR FEED	SUPPLIED FROM BAGGER
LABEL SIZE	UP TO 4 INCHES (102 MM) WIDE, 20 INCHES (508 MM) LONG

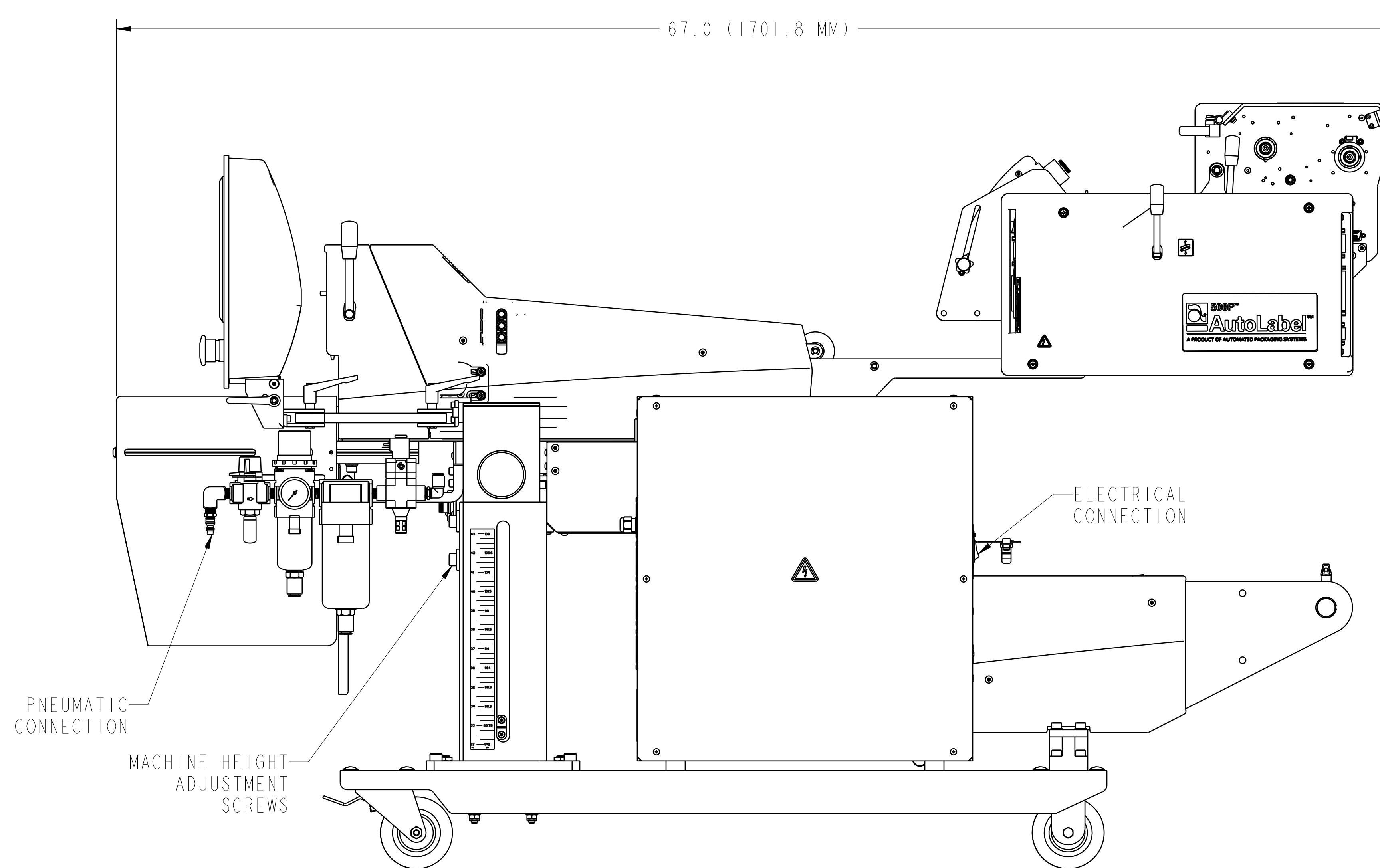
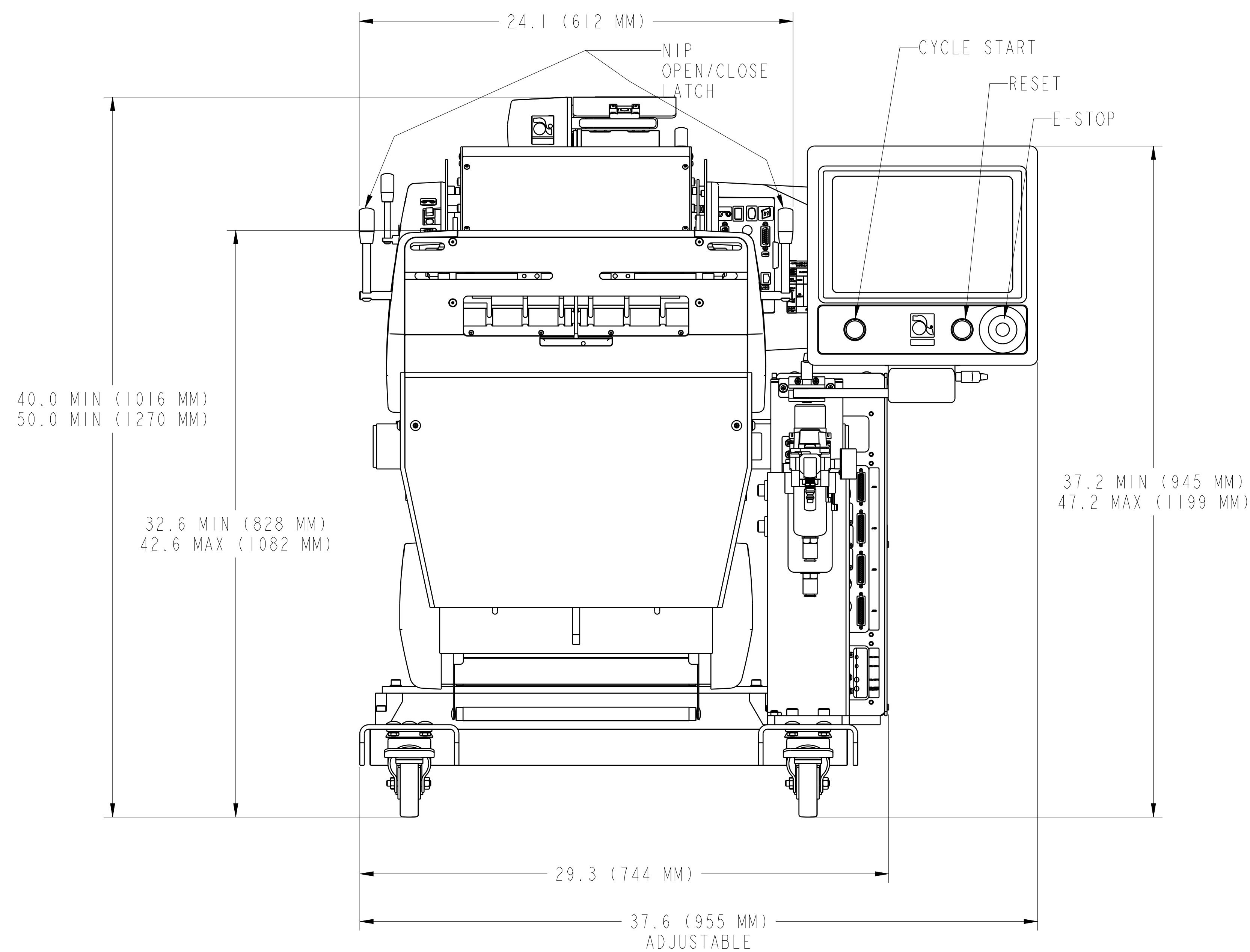

REV	BY	DATE	ECN	DESCRIPTION
B	DMF	7-1-21	3265	UPDATED POWER CONSUMPTION: 500W MAX 1500W, 300W MAX 2.4kW
A	DMF	11-15-20	2895	RELEASED

FINISH	NONE
MATERIAL	NONE
NOTES:	<p>MACHINE SURFACES TO BE NO GREATER THAN 125 (3.2) ✓</p> <p>SHARP EDGES MUST BE FILED TO ROUNDS AND SHARP EDGES</p> <p>FILED TO ROUNDS</p> <p>FILED TO ROUNDS</p> <p>FILED TO ROUNDS</p> <p>FILED TO ROUNDS</p>
SCALE	1/4
DATE	11-15-20

FOOTPRINT, AB500 & AL500P W/UNWIND	FP273
------------------------------------	-------